

ASCO™ Solenoid Valve

2/2 Normally Closed – Direct Acting - G 1/8

Series
L120-V07-V15

Features

- Direct acting solenoid valve, small body size
- Suitable to shut off liquid and gaseous fluids
(verify the compatibility of fluid with material in contact)

Technical Features

Maximum Allowable Pressure (PS)	40 bar
Opening Time	~20ms
Closing Time	~20ms
Fluid Temperature	0°C +130°C
Max Viscosity	5°E (~37 cStokes or mm ² /s)

Coil

Approval	UL/IMQ; UL (class F) – for UL cl. H: ZA34 (E153691)	
Continuous Duty	ED 100%	
Encapsulation Material	PPS (Polyphenilsulfure) fiberglass reinforced	
Insulation Class	F (155°C) on request class H (180°C)	
Ambient Temperature	-10°C +50°C	
Electric Connections	DIN 46340 - 3 poles plug-connectors (EN175301-803)	
Protection Degree	IP67 (EN 60529) with plug-connector	
Voltages	DC	12-24V (+10% -5%)
	AC	24V/50Hz - 110V/50Hz (120V/60Hz) - 230V/50Hz (+10% -15%) (Other voltages and frequencies on request)

Materials in Contact with Fluid

Body	Brass & brass low lead content only for L120V15
Sealing	FPM
Internal Components	Stainless steel
Seat	Stainless steel
Core Tube	Stainless steel
Shading Coil	Copper

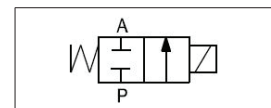

Port Size ISO 228 (NPT/G)	Orifice Size (mm)	Δp Min	Differential Pressure (bar)				Kv (m ³ /h)	Series and Type		Power Absorption			Sealings	Notes	Weight (kg)
			Δp Max					Valve	Coil	AC (VA)		DC (W)			
			Gases		Liquids					Inrush	Holding				
G 1/8	2.3	0	AC	DC	AC	DC	0.15	L120V07 L120V15	ZA10A	23	14	9	FPM	1 - 2 1 - 2 - 3	0.260

Sealings: FPM=Fluoro-carbon elastomer
 IMQ CSV approval, see ZA10 datasheet for further details
 1- Solenoid valve with stainless steel seat.
 2 - On request special coil ZA10X, class "F", with UL homologated windings – see overleaf.
 3 - D.M 174/2004 and CE 1935/2004 approved

Coil for Special Voltages ZA10X

Approval	UL (class F); see voltages	
Continuous Duty	ED 100%	
Encapsulation Material	PPS (Polyphenilsulfure) fiberglass reinforced	
Insulation Class	F (155°C)	
Ambient Temperature	-10°C +50°C	
Electric Connection	DIN 46340 - 3 poles plug-connectors (EN175301-803)	
Protection Degree	IP 67 (EN 60529) with plug-connector	
Voltages	AC	24V/50-60Hz (UL) • 100V/50-60Hz 115-120V/60Hz • 200V/50-60Hz 220-230V/50Hz - 208-240V/60Hz (UL) 220-240V/50Hz (UL) • (+10% -15%)

Port Size ISO 228	Orifice Size (mm)	Δp Min	Differential Pressure (bar)				Kv (m ³ /h)	Series and Type		Power Absorption			Sealings	Notes	Weight (kg)
			Δp Max					Valve	Coil	AC (VA)		DC (W)			
			Gases		Liquids					Inrush	Holding				
G 1/8	2.3	0	AC	DC	AC	DC	0.15	L120V07 L120V15	ZA10X	23	14	-	FPM	1	0.270

Sealings: FPM=Fluoro-carbon elastomer
 1- Solenoid valve with stainless steel seat.

1503/1605 Availability, design and specifications are subject to change without notice. All rights reserved.

Spare Parts

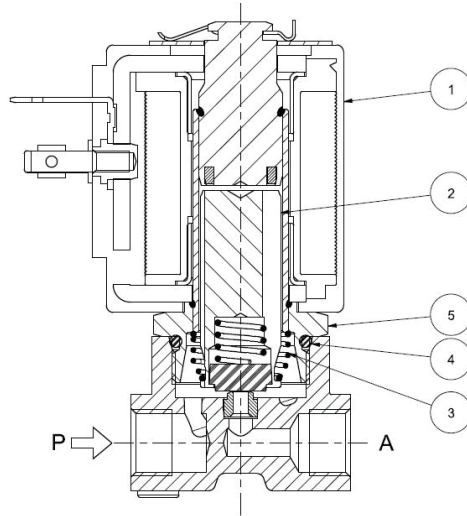

Kit Description	Kit P.N.	Consisting of
Core kit	G3022803	Core (with core return spring) pos. 2 or guide assembly pos.4
Core return spring kit	G3022401	N.10 core return spring pos. 3
OR guide assembly kit	GU2424000017	N.10 or guide assembly pos. 4
Guide assembly kit	G31486	Guide assembly pos. 5 Coil clip
Coil	ZA10A ZA10X	Coil pos. 1

Installation

- Solenoid valve can be mounted in any position; vertical with coil upwards preferred.

DIMENSIONS (mm)

